



ProMachine

OSNOVE KONSTRUISANJA - MATURSKI RAD

Proracun zupcastog prenosnika - ZADATAK 8

Zupcasti prenosnik razvodi snagu elektromotora na spojnice S1 i S2, pri cemu je $P_{S1} = 15 \text{ kW}$, a $P_{S2} = 21.5 \text{ kW}$. Osnovni podaci: $n_{EM} = 1460 \text{ min}^{-1}$, $z_1 = 17$, $z_2 = 49$, $z_5 = 19$, $z_6 = 96$, koeficijent pomeranja profila $x_5 = 0$, $x_6 = 0$, materijal zupcanika z5 je C.4320, stepen iskoristenja zupcastih parova $\eta_{1,2} = 0.97$, $\eta_{3,4} = 0.98$, $\eta_{5,6} = 0.98$. Gubitke u lezajima zanemariti. Opterecenje radnih masina je ravnomerno ($K_A = 1$).

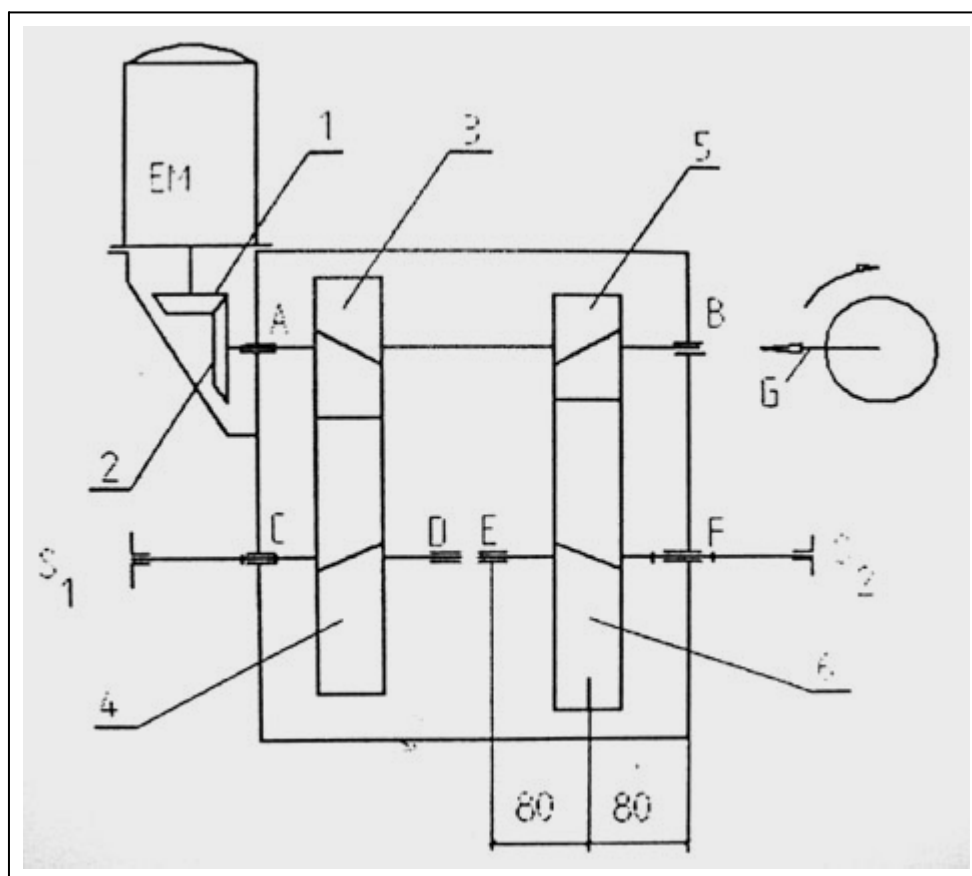

1. Izvršiti analizu sila datog prenosnika i nacrtati sheme opterećenja vratila AB i EF u horizontalnoj i vertikalnoj ravni
2. Odrediti izlazni broj obrtaja n_{S2} i izlaznu ugaonu brzinu ω_{S2}
3. Uzimajući u obzir gubitke u prenosniku odrediti obrtne momente T_6 , T_5 i potrebnu snagu elektromotora P_{EM}
4. Proracunati $m_{n5,6}$ preko cvrstoće bokova zubaca ako je $\phi_{5,6} = 1$, stepen sigurnosti bokova $S_H = 1.2$, ugao nagiba zubaca $\beta_{5,6} = 16 \text{ deg}$. Usvojiti $K_H = 1.5$.

5. Proracunati ugao $\beta_{5,6}$ (zaokruženo na cele minute), tako da osno rastojanje zupcastog para 5, 6 bude $a_{5,6} = 180 \cdot \text{mm}$. U daljem toku proračuna koristiti ovaj ugao.
6. Odrediti sledece geometrijske karakteristike: $m_{t5,6}$; $\alpha_{t5,6}$; d_5 ; d_6 ; d_{b5} ; d_{b6} ; d_{a5} ; d_{a6}
7. Odrediti stepen sprezanja profila ε_α i bokova ε_β .
8. Proveriti stepen sigurnosti podnozja zubaca zupcanika z5. Usvojiti $Y_\beta = 0.86$, $K_{V\beta} = 1.02$, $K_{F\beta} = 1.25$.
9. Dimenzionisati vratilo EF na mestu zupcanika z6. Materijal vratila C. 0645. Usvojiti $S = 5$. Dijagrame NE crtati.
10. Usvojiti klin bez nagiba za vezu zupcanika z6 i vratila EF. Usvojiti $l_k = 58 \cdot \text{mm}$. Odrediti povrinski pritisak izmedju glavnice zupcanika i klina. Koliki je povrinski pritisak, ako se veza ostvari sa dva klina?
11. Proracunati nazivni vek lezaja 6215 ugradjenog u oslonac F.

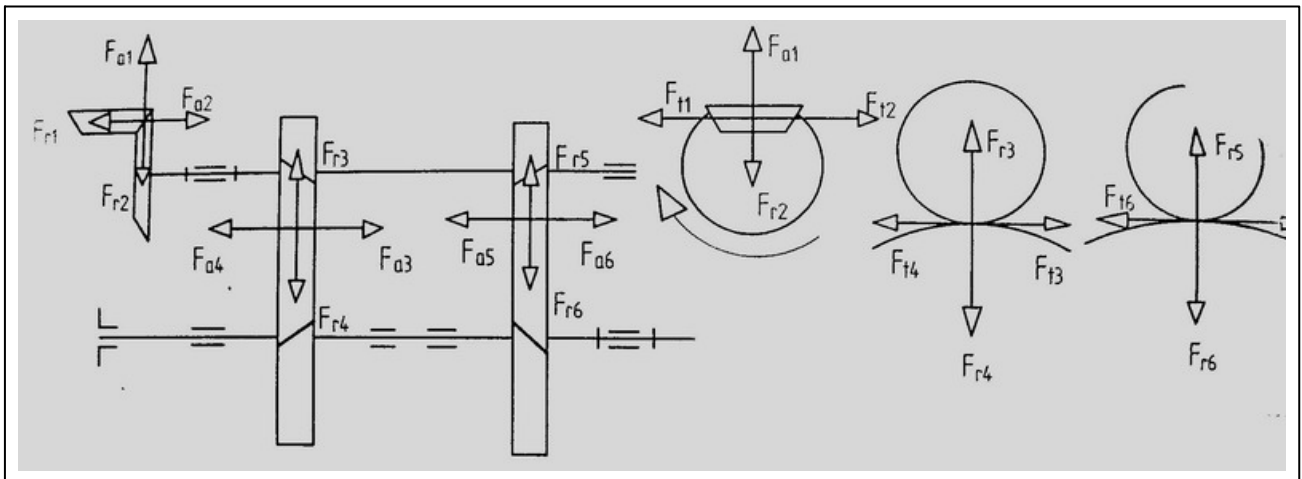
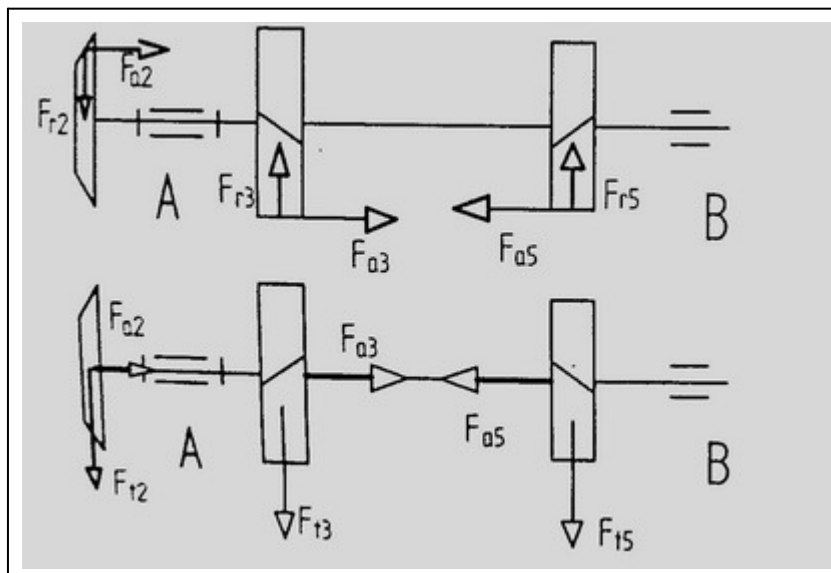
Resenje:**Tacka 1.**Schema opterećenja vratila AB

Shema opterećenja vratila EF

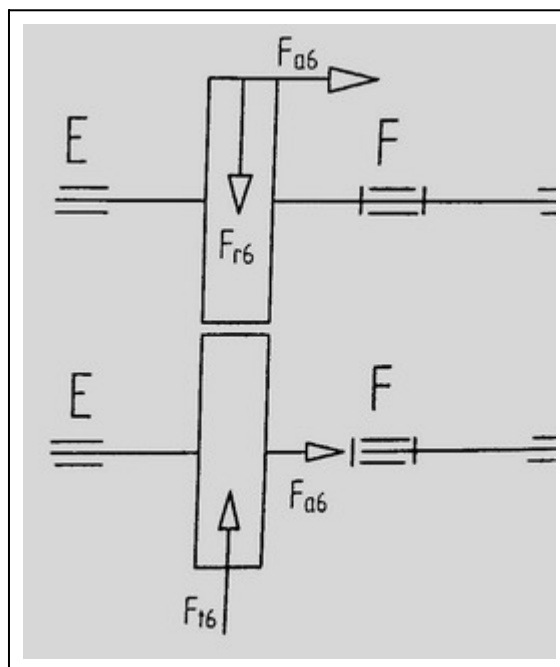

Tacka 2.

$$u_{1,2} = \frac{z_2}{z_1} \quad u_{1,2} = 2.882$$

$$u_{5,6} = \frac{z_6}{z_5} \quad u_{5,6} = 5.053$$

$$n_{S2} = \frac{n_{EM}}{u_{1,2} \cdot u_{5,6}}$$

$$n_{S2} = 100.251 \text{ min}^{-1}$$

$$\omega_{S2} = 2 \cdot \pi \cdot n_{S2}$$

$$\omega_{S2} = 10.498 \text{ s}^{-1}$$

Tacka 3.

$$\omega_{EM} = 2 \cdot \pi \cdot n_{EM} \quad \omega_{EM} = 152.891 \text{ s}^{-1}$$

$$T_{S2} = \frac{P_{S2}}{\omega_{S2}}$$

$$T_{S2} = 2.048 \times 10^3 \text{ N}\cdot\text{m}$$

$$T_6 = T_{S2}$$

$$T_6 = 2.048 \times 10^3 \text{ N}\cdot\text{m}$$

$$T_5 = \frac{T_6}{u_{5,6} \cdot \eta_{5,6}}$$

$$T_5 = 413.598 \text{ N}\cdot\text{m}$$

$$P_{EM} = \frac{\frac{P_{S1}}{\eta_{3,4}} + \frac{P_{S2}}{\eta_{5,6}}}{\eta_{1,2}}$$

$$P_{EM} = 38.397 \text{ kW}$$

Tacka 4.

$$d_5 = \sqrt[3]{\frac{2 \cdot T_5}{\phi_{5,6} \cdot \sigma_d^2} \cdot \frac{u_{5,6} + 1}{u_{5,6}} \cdot K_H \cdot Z^2}$$

$$\phi_{5,6} = 1$$

$$\sigma_{Hlim} = 1480 \cdot \frac{N}{mm^2}$$

$$S_H = 1.2$$

$$\sigma_d = \frac{\sigma_{Hlim}}{S_H} \quad \sigma_d = 1.233 \times 10^3 \frac{N}{mm^2}$$

$$u_{5,6} = 5.053$$

$$K_H = 1.5$$

$$Z_E = 189 \sqrt{\frac{N}{mm^2}}$$

$$Z = 2.5 \cdot Z_E \cdot \cos(\beta_{5,6})$$

$$Z = 454.196 \sqrt{\frac{N}{mm^2}}$$

$$d_5 = \sqrt[3]{\frac{2 \cdot T_5}{\phi_{5,6} \cdot \sigma_d^2} \cdot \frac{u_{5,6} + 1}{u_{5,6}} \cdot K_H \cdot Z^2}$$

$$d_5 = 58.634 \text{ mm}$$

$$m_{n5,6} = \frac{d_5}{z_5} \cdot \cos(\beta_{5,6}) \quad m_{n5,6} = 2.966 \text{ mm}$$

$$m_{n5,6} = 3 \cdot \text{mm}$$

Tacka 5.

$$a = \frac{m_n}{2 \cdot \cos(\beta)} \cdot (z_1 + z_2)$$

$$\beta_{5,6} = \arccos \left[\frac{m_{n5,6} \cdot (z_5 + z_6)}{2 \cdot a_{5,6}} \right]$$

$$\beta_{5,6} = 16.598 \text{ deg}$$

Tacka 6.

$$m_{t5,6} = \frac{m_{n5,6}}{\cos(\beta_{5,6})} \quad m_{t5,6} = 3.13043 \text{ mm}$$

$$\alpha_n = 20 \cdot \text{deg}$$

$$\alpha_{t5,6} = \text{atan}\left(\frac{\tan(\alpha_n)}{\cos(\beta_{5,6})}\right) \quad \alpha_{t5,6} = 20.797 \text{ deg}$$

$$d_5 = m_{t5,6} \cdot z_5 \quad d_5 = 59.478 \text{ mm}$$

$$d_6 = m_{t5,6} \cdot z_6 \quad d_6 = 300.522 \text{ mm}$$

$$d_{b5} = d_5 \cdot \cos(\alpha_{t5,6}) \quad d_{b5} = 55.603 \text{ mm}$$

$$d_{b6} = d_6 \cdot \cos(\alpha_{t5,6}) \quad d_{b6} = 280.942 \text{ mm}$$

$$d_{a5} = d_5 + 2 \cdot m_{n5,6} \quad d_{a5} = 65.478 \text{ mm}$$

$$d_{a6} = d_6 + 2 \cdot m_{n5,6} \quad d_{a6} = 306.522 \text{ mm}$$

$$d_{f5} = d_5 - 2.4 \cdot m_{n5,6} \quad d_{f5} = 52.278 \text{ mm}$$

$$d_{f6} = d_6 - 2.4 \cdot m_{n5,6} \quad d_{f6} = 293.322 \text{ mm}$$

Tacka 7.

$$\varepsilon_\alpha = \frac{g_\alpha}{p_{bt}}$$

$$\alpha_{wt5,6} = \alpha_{t5,6} \quad \text{jer je} \quad x_5 = 0 \quad x_6 = 0$$

$$g_\alpha = \sqrt{\left(\frac{d_{a5}}{2}\right)^2 - \left(\frac{d_{b5}}{2}\right)^2} + \sqrt{\left(\frac{d_{a6}}{2}\right)^2 - \left(\frac{d_{b6}}{2}\right)^2} - a_{5,6} \cdot \sin(\alpha_{wt5,6})$$

$$g_\alpha = 14.673 \text{ mm}$$

$$p_n = \pi \cdot m_n$$

$$p_t = \pi \cdot m_t$$

$$p_{bt} = p_t \cdot \cos(\alpha_t)$$

$$p_{t5,6} = \pi \cdot m_{t5,6} \quad p_{t5,6} = 9.835 \text{ mm}$$

$$p_{bt5,6} = \pi \cdot m_{t5,6} \cdot \cos(\alpha_{t5,6}) \quad p_{bt5,6} = 9.194 \text{ mm}$$

$$\varepsilon_{\alpha} = \frac{g_{\alpha}}{P_{bt5,6}}$$

$$\varepsilon_{\alpha} = 1.596$$

$$\varepsilon_{\beta} = \frac{g_{\beta}}{P_t}$$

$$b = \phi_{5,6} \cdot d_5 \quad b = 59.478 \text{ mm} \quad \text{usvajam} \quad b_5 = 60 \cdot \text{mm}$$

$$g_{\beta} = b_5 \cdot \tan(\beta_{5,6}) \quad g_{\beta} = 17.884 \text{ mm}$$

$$\varepsilon_{\beta} = \frac{g_{\beta}}{P_{t5,6}}$$

$$\varepsilon_{\beta} = 1.819$$

Tacka 8.

$$\sigma_{F5} = Y_{Fa} \cdot Y_{Sa} \cdot Y_{\varepsilon} \cdot Y_{\beta} \cdot \frac{F_{t5}}{b_5 \cdot m_{n5,6}} \cdot K_A \cdot K_V \cdot K_{F\beta}$$

$$Y_{Fa} = 2.85$$

$$z_{n5} = \frac{z_5}{\cos(\beta_{5,6})^3} \quad z_{n5} = 21.588$$

$$x_5 = 0$$

$$Y_{Sa} = 1.68$$

$$Y_{\varepsilon} = 0.25 + \frac{0.75}{\varepsilon_{\alpha}} \quad Y_{\varepsilon} = 0.72$$

$$Y_{\beta} = 0.86$$

$$F_{t5} = \frac{2 \cdot T_5}{d_5} \quad F_{t5} = 13.908 \times 10^3 \text{ N}$$

$$b_5 = 0.06 \text{ m}$$

$$m_{n5,6} = 3 \text{ mm}$$

$$K_A = 1$$

$$K_V = K_{V\beta} \quad \text{za } \varepsilon_{\beta} > 1 \quad K_V = 1.02$$

$$K_{F\beta} = 1.25$$

$$\sigma_{F5} = Y_{Fa} \cdot Y_{Sa} \cdot Y_{\varepsilon} \cdot Y_{\beta} \cdot \frac{F_{t5}}{b_5 \cdot m_{n5,6}} \cdot K_A \cdot K_V \cdot K_{F\beta} \quad \sigma_{F5} = 292.032 \frac{\text{N}}{\text{mm}^2}$$

$$\sigma_{F5M} = Y_{II} \cdot \sigma_{Flim}$$

$$Y_{II} = 2 \quad \text{za } m_n \leq 5 \quad \text{i} \quad R_a \leq 10 \cdot \mu\text{m}$$

$$Y_{II} = 1.7 + 2 \quad \text{za } m_n > 5 \quad \text{i/ili} \quad R_a > 10 \cdot \mu\text{m}$$

$$Y_{II} = 2 \quad \text{za } m_{n5,6} = 3 \text{ mm}$$

$$\sigma_{Flim} = 416 \cdot \frac{N}{\text{mm}^2}$$

$$\sigma_{F5M} = Y_{II} \cdot \sigma_{Flim}$$

$$\sigma_{F5M} = 832 \cdot \frac{N}{\text{mm}^2}$$

$$S_{F5} = \frac{\sigma_{F5M}}{\sigma_{F5}}$$

$$S_{F5} = 2.849$$

Tacka 9.

$$F_{t6} = \frac{2 \cdot T_6}{d_6}$$

$$F_{t6} = 1.363 \times 10^4 \text{ N}$$

$$F_{r6} = \frac{F_{t6}}{\cos(\beta_{5,6})} \cdot \tan(\alpha_n)$$

$$F_{r6} = 5.176 \times 10^3 \text{ N}$$

$$F_{a6} = F_{t6} \cdot \tan(\beta_{5,6})$$

$$F_{a6} = 4.063 \times 10^3 \text{ N}$$

$$l = 80 \text{ mm}$$

$$\sum_H M_E = 0 \quad Y_{FH} \cdot 2 \cdot l - F_{r6} \cdot l - F_{a6} \cdot \frac{d_6}{2} = 0 \quad Y_{FH} = \frac{F_{r6} \cdot l + F_{a6} \cdot \frac{d_6}{2}}{2 \cdot l}$$

$$Y_{FH} = 6.403 \times 10^3 \text{ N}$$

$$Y_{FV} = \frac{F_{t6}}{2}$$

$$Y_{FV} = 6.815 \times 10^3 \text{ N}$$

$$M_{6-\varepsilon H} = Y_{FH} \cdot l - F_{a6} \cdot \frac{d_6}{2}$$

$$M_{6-\varepsilon H} = -98.165 \text{ N}\cdot\text{m}$$

$$M_{6+\varepsilon H} = Y_{FH} \cdot l$$

$$M_{6+\varepsilon H} = 512.275 \text{ N}\cdot\text{m}$$

$$M_{6V} = Y_{FV} \cdot l$$

$$M_{6V} = 545.175 \text{ N}\cdot\text{m}$$

$$M_6 = \sqrt{M_{6+\varepsilon H}^2 + M_{6V}^2}$$

$$M_6 = 748.092 \text{ N}\cdot\text{m}$$

$$T_6 = 2.048 \times 10^3 \text{ N}\cdot\text{m}$$

$$M_{i6} = \sqrt{M_6^2 + (\alpha \cdot T_6)^2}$$

$$\sigma_{D(-1)s} = 280 \frac{\text{N}}{\text{mm}^2}$$

$$\tau_{D(0)u} = 200 \frac{\text{N}}{\text{mm}^2}$$

$$\alpha = \frac{\sigma_{D(-1)s}}{2 \cdot \tau_{D(0)u}}$$

$$\alpha = 0.7$$

$$M_{i6} = \sqrt{M_6^2 + (\alpha \cdot T_6)^2}$$

$$M_{i6} = 1.617 \times 10^3 \text{ N}\cdot\text{m}$$

$$S = 5$$

$$\sigma_d = \frac{\sigma_{D(-1)s}}{S}$$

$$\sigma_d = 56 \frac{\text{N}}{\text{mm}^2}$$

$$d_{i6} = \sqrt[3]{\frac{32 \cdot M_{i6}}{\pi \cdot \sigma_d}}$$

$$d_{i6} = 66.503 \text{ mm}$$

$$d_{v6} = 1.2 \cdot d_{i6}$$

$$d_{v6} = 79.804 \text{ mm}$$

$$d_{v6} = 80 \text{ mm}$$

Tacka 10.

$$d_{v6} = 80 \text{ mm}$$

usvajam klin

$$b = 22 \text{ mm}$$

$$h = 14 \text{ mm}$$

$$t = 8.5 \text{ mm}$$

$$r = 0.6 \text{ mm}$$

$$l_k = 58 \text{ mm}$$

$$l = l_k + b$$

$$l = 80 \text{ mm}$$

usvajam

$$l = 80 \text{ mm}$$

dakle,

22 x 14 x 80 - C.0645 - JUS M.C2.060

$$p_2 = \frac{F_{tk}}{t_2 \cdot l_k}$$

$$F_{tk} = \frac{2 \cdot T_6}{d_{v6}}$$

$$F_{tk} = 51.199 \times 10^3 \text{ N}$$

$$t_2 = h - t$$

$$t_2 = 5.5 \text{ mm}$$

$$p_2 = \frac{F_{tk}}{t_2 \cdot l_k}$$

$$p_2 = 160.499 \frac{\text{N}}{\text{mm}^2}$$

$$p_{22k} = \frac{F_{tk}}{2 \cdot t_2 \cdot l_k}$$

$$p_{22k} = 80.249 \frac{\text{N}}{\text{mm}^2}$$

Tacka 11.

leza 6215

$$d = 75 \cdot \text{mm}$$

$$C = 50 \cdot 10^3 \cdot \text{N}$$

$$C_0 = 42.5 \cdot 10^3 \cdot \text{N}$$

$$F_r = \sqrt{Y_{FV}^2 + Y_{FH}^2} \quad F_r = 9.351 \times 10^3 \text{ N}$$

$$F_a = F_{a6} \quad F_a = 4.063 \times 10^3 \text{ N}$$

$$\frac{F_a}{C_0} = 0.096 \quad e = 0.29$$

$$\frac{F_a}{F_r} = 0.434 \quad \frac{F_a}{F_r} > e \quad X = 0.56$$

$$Y = 1.5$$

$$F = X \cdot F_r + Y \cdot F_a \quad F = 11.33 \times 10^3 \text{ N}$$

$$f_t = 1$$

$$\alpha = 3$$

$$L = \left(\frac{C \cdot f_t}{F} \right)^\alpha \cdot 10^6 \quad L = 85.935 \times 10^6$$

$$n_6 = n_{S2} \quad n_6 = 100.251 \text{ min}^{-1}$$

$$L_h = \frac{L}{n_6} \quad L_h = 14.3 \times 10^3 \text{ hr}$$